

# Real-Time IoT-Based Health Care Monitoring for Prediction and Analysis

Komal Mukesh Adkane, Prof. Anil Bavaskar

**Abstract**— Care of critically ill patient, requires spontaneous & accurate decisions so that life protecting & lifesaving therapy can be properly applied. Statistics reveal that every minute a human is losing his or her life across the globe. More close in India, everyday many lives are affected by heart attacks and more importantly because the patients did not get timely and proper help. This paper is based on monitoring of patients. We have designed and developed a reliable, energy efficient patient monitoring system. It is able to send parameters of patient in real time. It enables the doctors to monitor patient health parameters in real time. Here the parameters of patient are measured continuously and wirelessly transmitted using Zigbee. The project provides a solution for enhancing the reliability and flexibility by improving the performance and patient monitoring system. In the current proposed system the patient health is continuously monitored and the acquired data is analyzed at a centralized system. If a particular patient health parameter falls below the threshold value, a . Here, we are using Zigbee for wireless transmission. The Doctor can get are cord of a particular information by just accessing the database of the patient on his PC which is continuously updated through Zigbee receiver module.

**Index Terms**— wirelessly transmitted, Zigbee, PC

## I. INTRODUCTION

In recently, wireless sensor networks are used to structure Remote care system in many researches. Wireless sensor networks application for physiological signals communication transmission has many technologies. Such as the ZigBee, used for Physiological signal transmission. Although ZigBee has lower power consumption. Hence, ZigBee is used for 24 hours monitor of communication transmission systems. ZigBee provides higher network flexibility and a larger number of nodes, and a better transmission range with low power consumption. Large number of nodes enables the expansion of such systems. Recently, ZigBee based wireless networks were check in various applications. The proposed patient monitoring system would be beneficial for medical practitioners to do proper and treatment; also it would be useful for health care providers to improve disease management. The patient is monitored the data transferred to the PC is wired. Recent work [1,2] includes using Bluetooth technology coupled with the patient or his doctor. Monitoring based on ultra wideband based personal area networks was reported in [3]. Sneha and others [4] presented an architectural framework for a system that utilizes mobile techniques to wirelessly monitor patients. The work reported in [5] discusses the implementation issues, and describes the overall system architecture of a Bluetooth sensor network for patient monitoring in [6] the authors investigate the use of ZigBee

and in monitoring in patients with diabetes mellitus or heart diseases.

## II. LITERATURE SURVEY

The speed of change in the medical field has been overwhelming. Groundbreaking achievements such as the discovery and development of penicillin, chemotherapy, and vaccinations have led people in the medical profession to have a great understanding of the human body [1]. The average life expectancy in the United States has increased from 47.3 years in 1900 to 68.2 years in 1950 to 77.3 years in 2002 [2,3]. With such a high and continued increasing average life expectancy rate, medical care for senior citizens, age 65 and over, is becoming progressively more important. The evolution of wireless technology is also extremely fast-paced. The 802.11b protocol for wireless computer networks came in large demand in 2000. In just over four years, wireless communications technology has become readily available for the general public, with 7.5 million households in the U.S. using some form of a wireless network [4]. The benefits of wireless technology are already apparent: portability, convenience, ease of installation, and low cost. What if wireless and medical sensor technology were combined? In this paper, we discuss the design of a wearable device that can remotely monitor vital signs of users. This device is implemented using existing technologies. The information from this device is sent to a base station which is connected to a computer. The information will be received by medical personnel and/or family members. Several patients may be monitored from a single base station. The system is designed so that it is easy to use and set up in medical facilities (such as hospitals) and residences. One of the early works on health care monitoring system has been proposed in [6]. The proposed system is suitable for patients, senior citizens, and others who need continuous monitoring of their health. The proposed system can monitor the ECG signals of a patient based on Session Initiation Protocol (SIP) and a ZigBee network. The system consists of a wireless ECG sensor, ECG console, ZigBee module, SIP register, a proxy server, a database server, and wireless devices. Simultaneous monitoring of the biomedical signals from multiple patients has been addressed in

The proposed network is based on IEEE 802.15.4 standard and the ZigBee technology. The authors have proposed an optimized source routing protocol to control the network load. Some other issues including energy consumption, network lifetime, and delivery ratio have also been addressed in the same work leads to confusion because equations do not balance dimensionally. If you must use mixed units, clearly state the units for each quantity that you use in an equation.

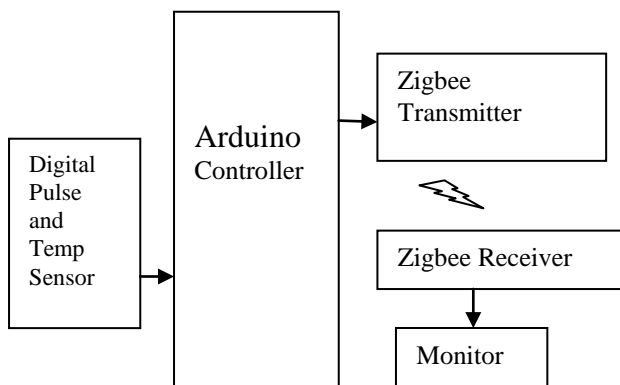

Figure 1. Block Diagram

### III. IMPLEMENTATION METHODOLOGY

Since the dawning of the age of electronics, countless attempts have been made to convince the medical profession of the advantage of amplifying hearts sounds with the idea that if the sound level could be increased a greater diagnostic capability might be achieved. The heart sound heard by the physician through his conventional stethoscope occur at the time of closure of major valves in the heart. In an abnormal heart additional hearts sounds. Murmurs are heard between the normal sounds. Murmurs are generally caused either by improper opening of the valves or by opening in the septum, which separates the left and the right side of the heart. Different physicians may hear the same sound but interpret them differently. This could lead to faulty diagnosis.

In addition high fidelity equipment would be able to reproduce the entire frequency range much of which is missed by the ordinary stethoscope. The instrument that has been developed in order to utilise the entire sound spectrum with high fidelity is the digital stethoscope from heart by means of suitable hardware. The extracted signal is feed to computer to detect for abnormalities of the heart if any Measurement of physiological parameters like heart rate and respiration rate crucial in the field of medicine. Advances in technology have provides different measurements for constantly monitoring Here is a simple method for respiration rate measurement using a displacement transducer. This meter can be used to monitor the respiration rate, pulse rate (by using a proper sensor) and heart rate. It responds fast and is cost-effective compared to conventional medical equipment. By using this, respiration rate can be measured in the range can be measured in the range of 0-999 respirations/minute.

### IV. CIRCUIT DESCRIPTION

The respiration rate meter. It uses a displacement transducer for sensing the respiration rate using IR transmitter and receiver as shown in the physical assembly. Inhaling and exhaling the air during respiration leads to move of a lightweight ball (made of thermocal) up and down in a capillary glass tube. This movement is sensed with the help of IR transmitter-receiver assembly of the sensing circuit and converted into pulses through the pulse generator. These

pulses are counted for a minute using a counter. Start switch s1 is used to reset the display to zero and enable the counter for a minute to count the respiration pulse. The gate pulse generator consists of a monostable consists of a monostable multivibrator. When triggered by start switch, it generates gating pulse of one minute duration.

The circuit of the respiration rate meter. The IR transmitter LED (IRTX) connected in series with resistor R1 transmits IR signals, which are received by the IR receiver Led (IRTX).The IR receiver is connected to the base of transistor T1 through resistor R2. When the transmitter IR signal falls directly the reverse biased IR diode, it produces an electrical signal according to the IR intensity. So transistor T1 conducts and its collector goes low, which makes transistor T2 becomes high, which represent logic '1'. When the IR signal from the transmitter is interrupted due to movement of the ball up and down during the bale-exhale mechanism, transistor T1 is cut-off and its collector goes high, which drives transistor T2 into conduction. The collector of transistor T2 goes low, which represents logic '0'. This means whenever the ball crosses the IR beam, a pulse is generated during in bale and exhale. IR emits the rays amplified by transistor and generated by 555 timer. TSOP sense the signal and sends to the transistor Which has 555 timer sends to the microcontroller will has the programming which sends to decoder which trigger the relay Through which it will trigger the relay ON. certain frequency and ignores all other IR received. The best frequency for the job is between 30 and 60kHz, the most used is around 36kHz. So, remote controls use the 36kHz (or around) to transmit information. Infra Red light emitted by IR Diodes is pulsed at 36 thousand times per second, when transmitting logic level "1" and silence for "0". To generate a 36kHz pulsating infrared is quite easy, more difficult is to receive and identify this frequency. This is why some companies produce infrared receives, that contains the filters, decoding circuits and the output shaper, that delivers a square wave, meaning the existence or not of the 36kHz incoming pulsating infrared.

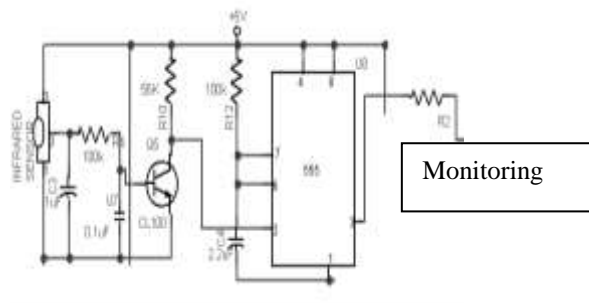

Figure 2. Pulse rate Detection Circuit

### V. CONCLUSION

For computerizing the working in a hospital. The software takes care of all the requirements of an average hospital and is capable to provide easy and effective storage of information related to patients that come up to the hospital. It generates test reports; provide prescription details including various tests, diet advice, and medicines prescribed to patient and doctor. It also provides injection details and billing facility on the basis of patient's status whether it is an indoor or outdoor patient. The system also provides the facility of backup as per the requirement.

REFERENCES

- [1] F. Tay, D. Guo, L. Xu, M. Nyan, and K. Yap, "MEMS Wearbiomonitoring System for Remote Vital Signs Monitoring," in *Journal of the Franklin Institute*, vol.346, no.6, pp.531 -542, August 2009.
- [2] A. Sagahyroon, H. Raddy, A. Ghazy, and U. Suleman , "Design and Implementation of a Healthcare Monitoring System," in *International Journal of Electronic Healthcare*, vol.5,no.1 pp.68 86, 2009.
- [3] K. Takizawa, Huan Bang, L. Kiyoshi, H. Kohno, "Wireless Vital Sign Monitoring using Ultra Wideband Based Personal Area Networks," in *Proc. of the International Conference of the IEEE Engineering Medicine in Biology Society*, pp. 1798 1801, August 2007.
- [4] S. Sneha and U. Varshney, "A Wireless ECG Monitoring System for Pervasive Healthcare," in *International Journal of Electronic Healthcare*, vol.3,no.1 pp. 50, 2007 Y. Zhang and H. Xiao, "Bluetooth Based Sensor Network for Remotely Monitoring the Physiological Signals of Patient," in *IEEE Trans. on Information Technology in Biomedicine*, vol.13,no.6 pp. 1040 1048, November 2009
- [6] H. Lee, S. Lee, K. Ha, H. Jang, W. Chung, J. Kim, Y. Chang, and D. Hoo, "Ubiquitous Healthcare Service Using ZigBee and Mobile for Elderly Patients," in *International Journal of Medical Informatics*, , no.3 pp. 193 198, March 2009.
- [7] Sahandi, R ., Noroozi, S., Roushanbakhti, G., Heaslip, V. & Liu, Y . "Wireless technology in the evolution of patient monitoring on general hospital wards". *Journal of Medical Engineering and Technology*, vol.34, no.1 pp. 51 63 ,2010
- [8] AliakseiKerhet, Michele .M,Francesco.L, Andrea. B, Luca. B. "A low power wireless video sensor node for distributed object detection," *Real Time Image Proc* , vol. 2 , pp. 331 342 , 2007